

(All hole locations are centered unless otherwise noted; distances from edges are to the centers of holes.)

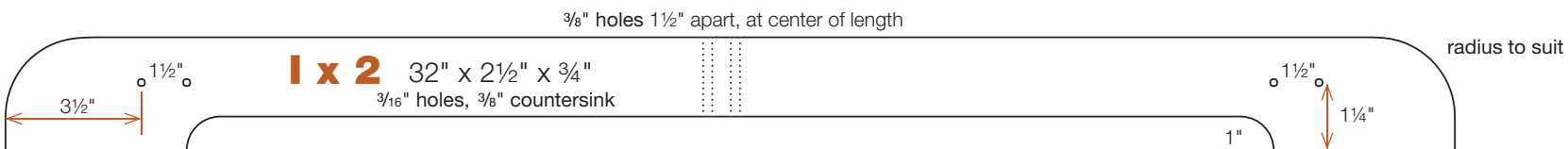
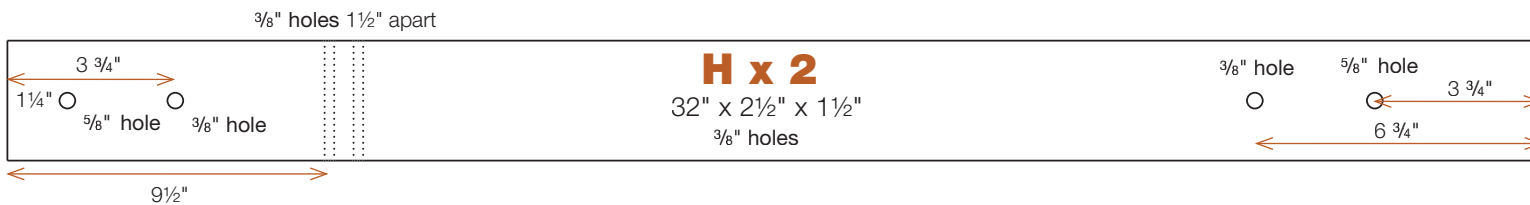
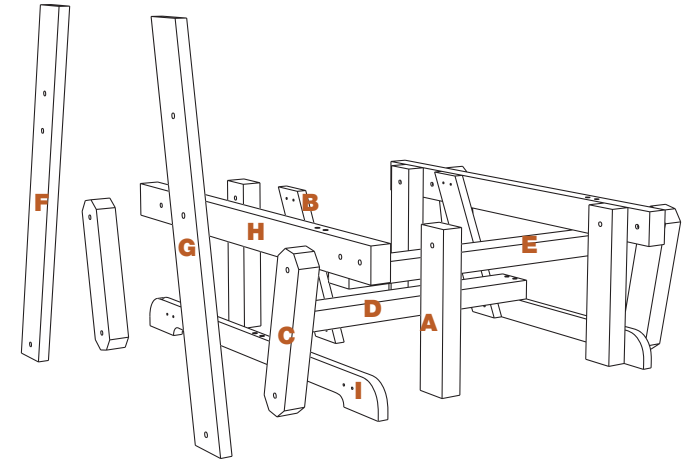
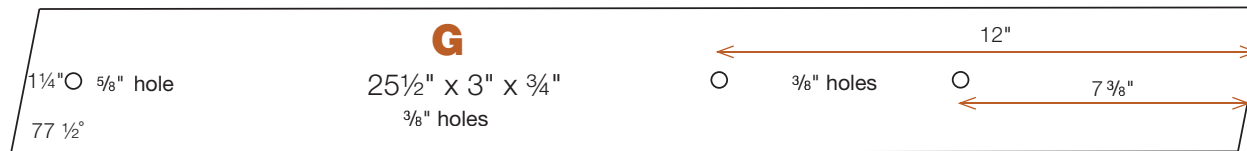
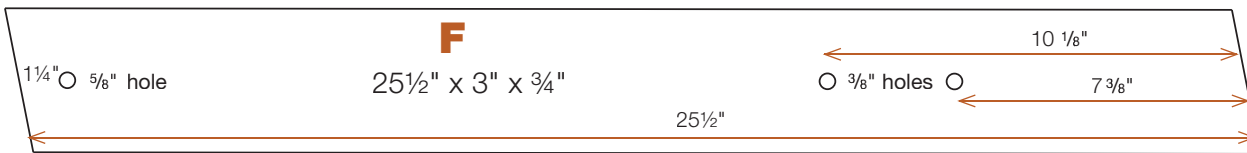

(All outlines are 1/4 scale; enlarge by 400% for final size.)

PROJECT NUMBER **53**  
**GLIDER FOR ONE**

SCALED OUTLINES AND SUPPLEMENTAL MEASUREMENTS  
 FOR CRADLE ASSEMBLY